

大腦的解題 ——神經網路簡介

產業研發碩士專班課程

陳慶瀚

機器智慧與自動化技術(MIAT)實驗室

義守大學電機系

pierre@isu.edu.tw

2005年11月01日



本週主題

1. 生物和人工的神經系統
2. 神經網路解題
3. 神經網路應用



生物和人工的神經系統



生物系統和人工系統

生物系統

人工系統

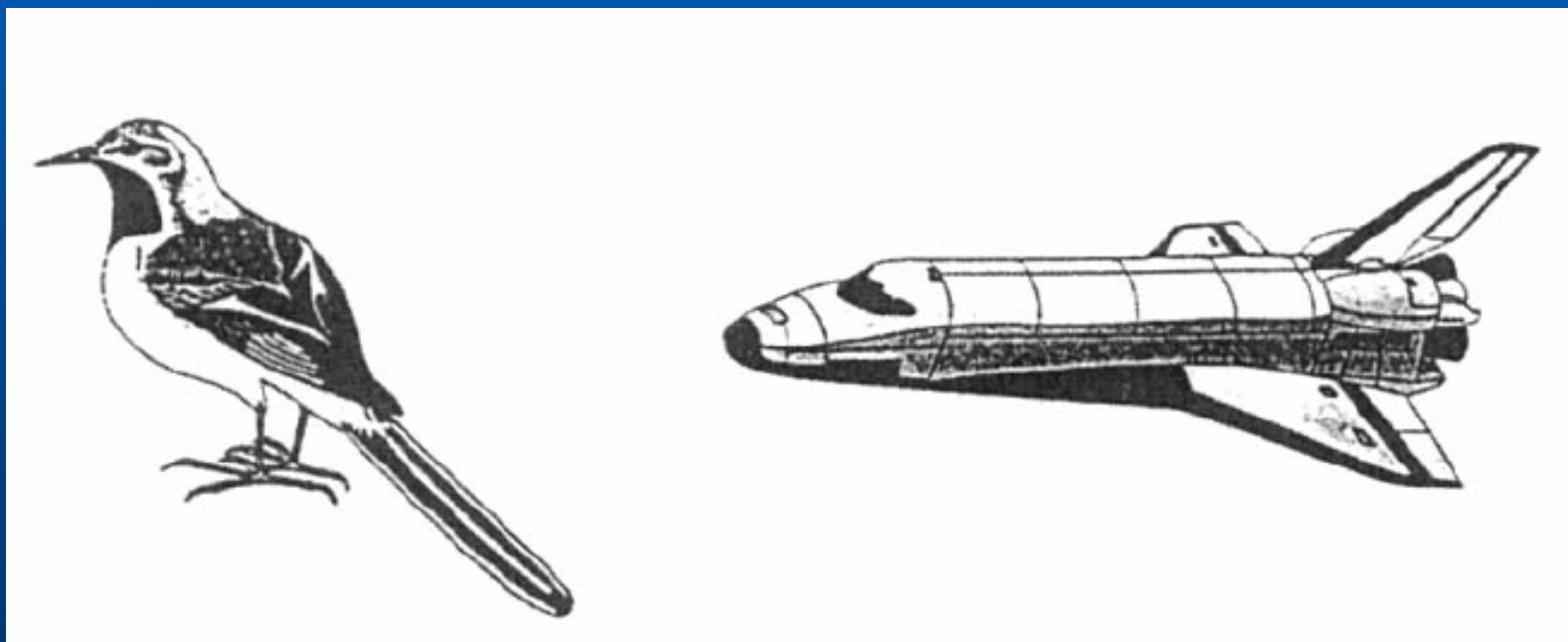



人腦與計算機

人腦

計算機

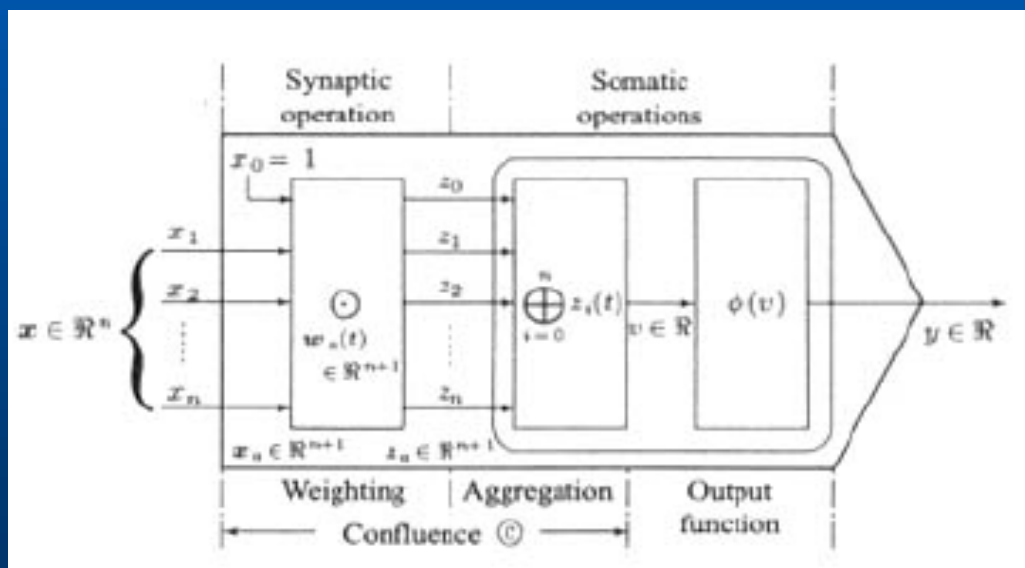



人工神經網路

人工神經網路是一種非線性的輸入/輸出映射系統，它的結構係參照人類及動物的神經系統來設計的。

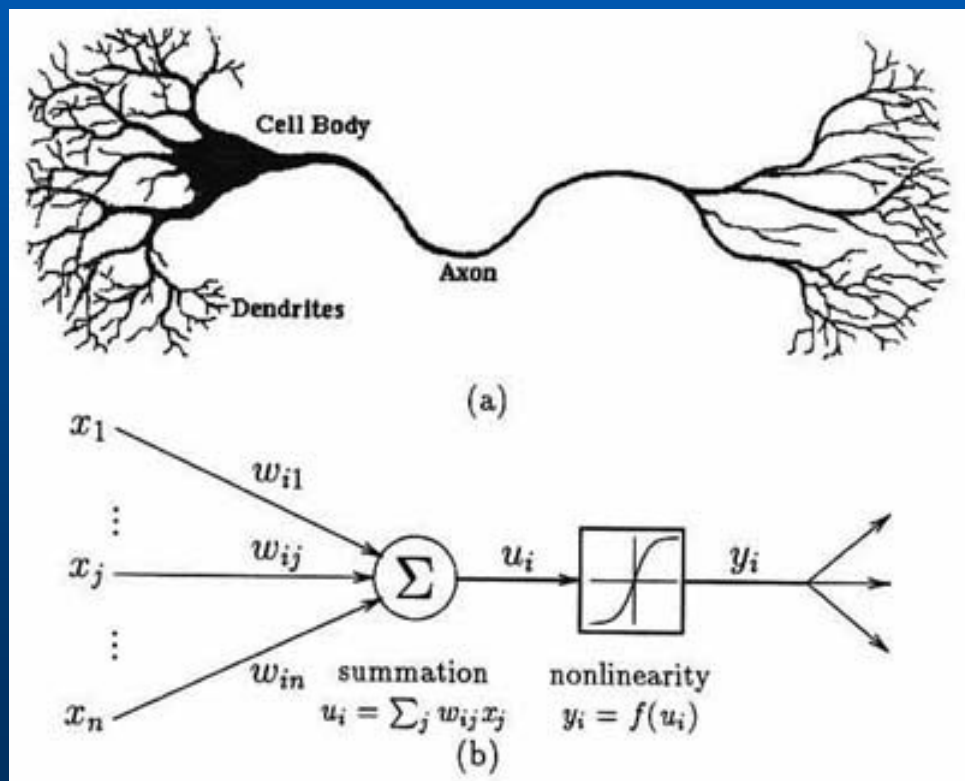



神經網路運作模型

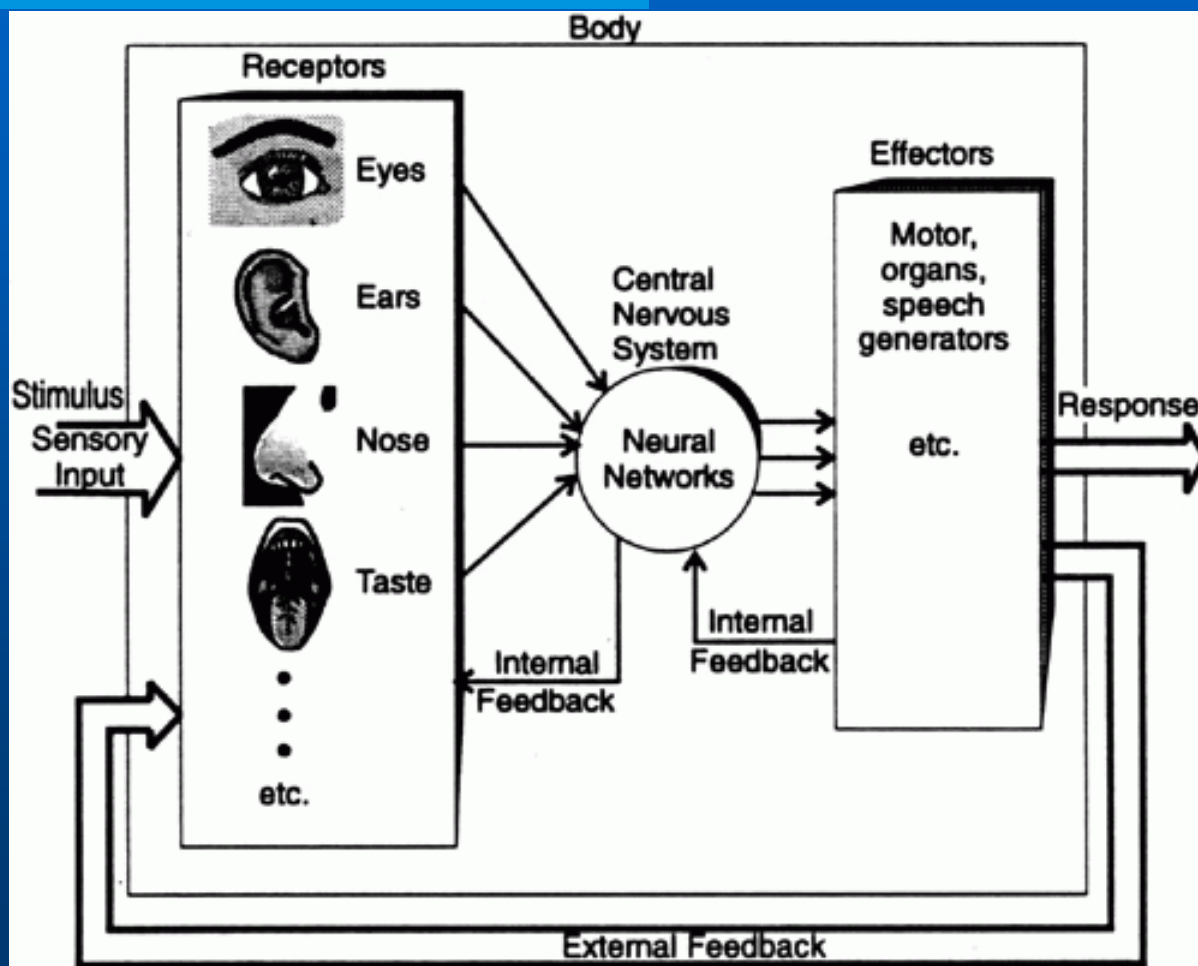



人工 V. S. 真實神經網路

| | 人工神經網路 | 真實神經網路 |
|-------|------------------|----------------|
| 結構 | 均質結構 | 非均質結構 |
| 資訊流 | 前向式(feedforward) | 遞迴式(recurrent) |
| 神經元數量 | 10~1000個 | 10^{11} 個 |
| 動力 | 靜態 | 動態 |



McCulloch-Pitts神經元模型

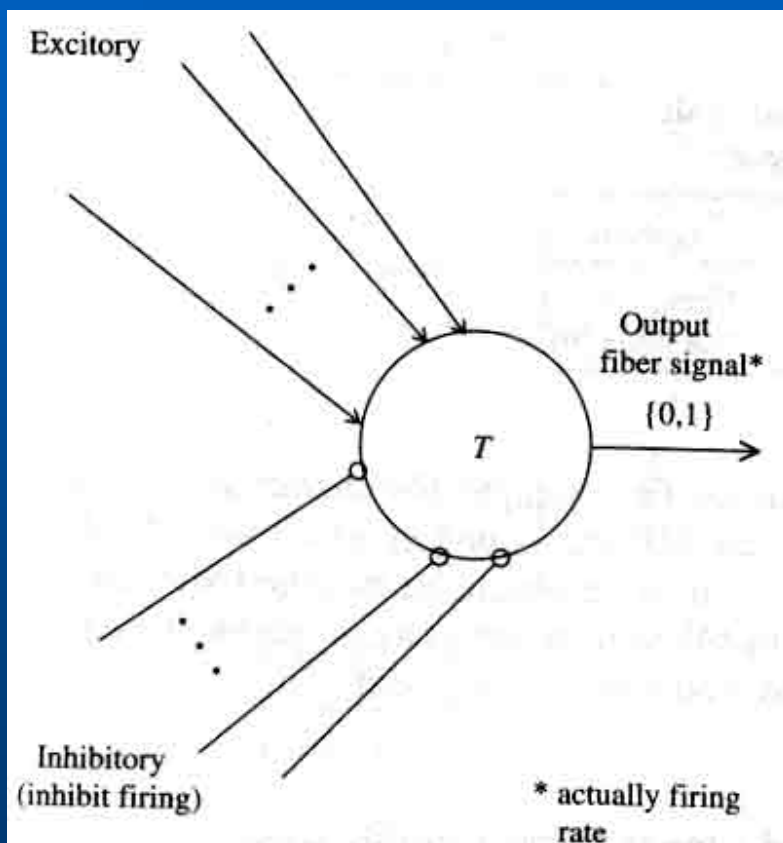

T : Threshold

E : Sum of activated excitatory inputs

I : Sum of activated inhibitory inputs

| | | |
|------------|---------|----------------|
| $E \geq T$ | $I = 0$ | Firing (1) |
| $E \geq T$ | $I > 0$ | Not firing (0) |
| $E < T$ | $I = 0$ | Not firing (0) |
| $E < T$ | $I > 0$ | Not firing (0) |



以神經元模擬邏輯函數

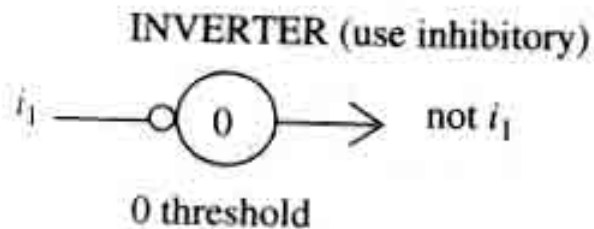
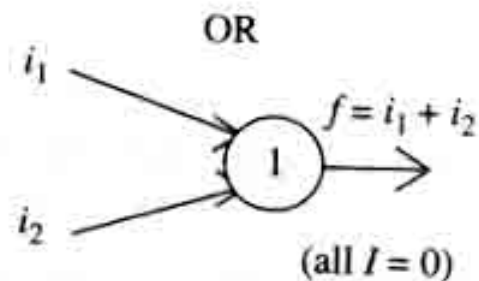
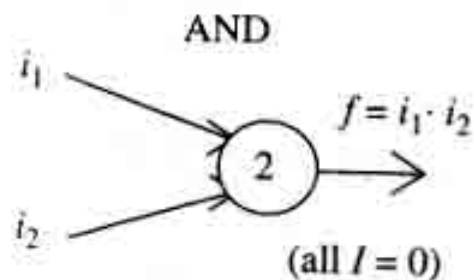



泛用途人工神經元模型

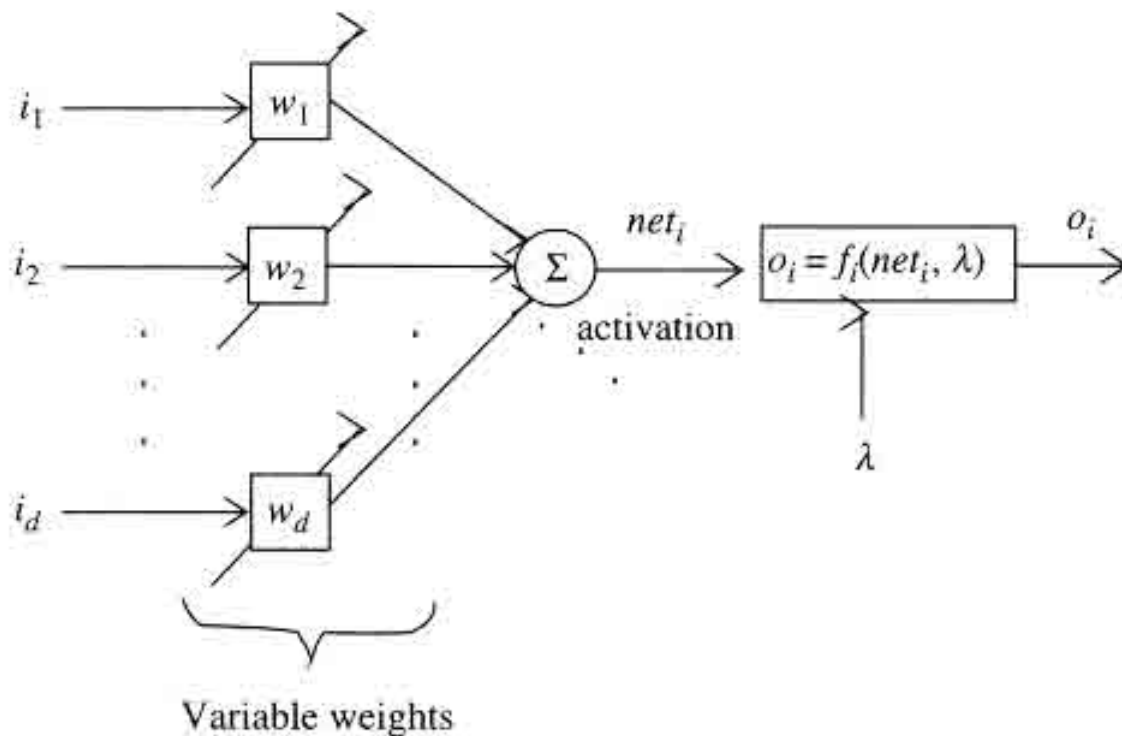



二元輸出的人工神經元模型

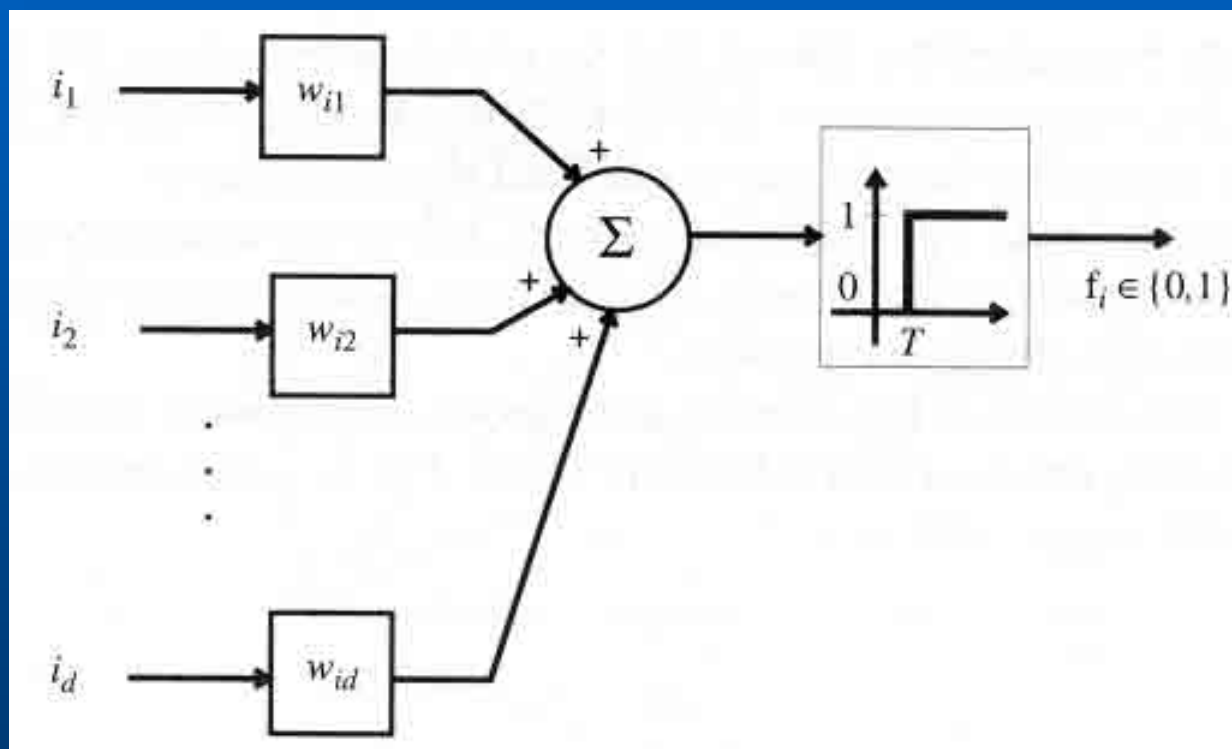



神經元的轉移函數：線性函數

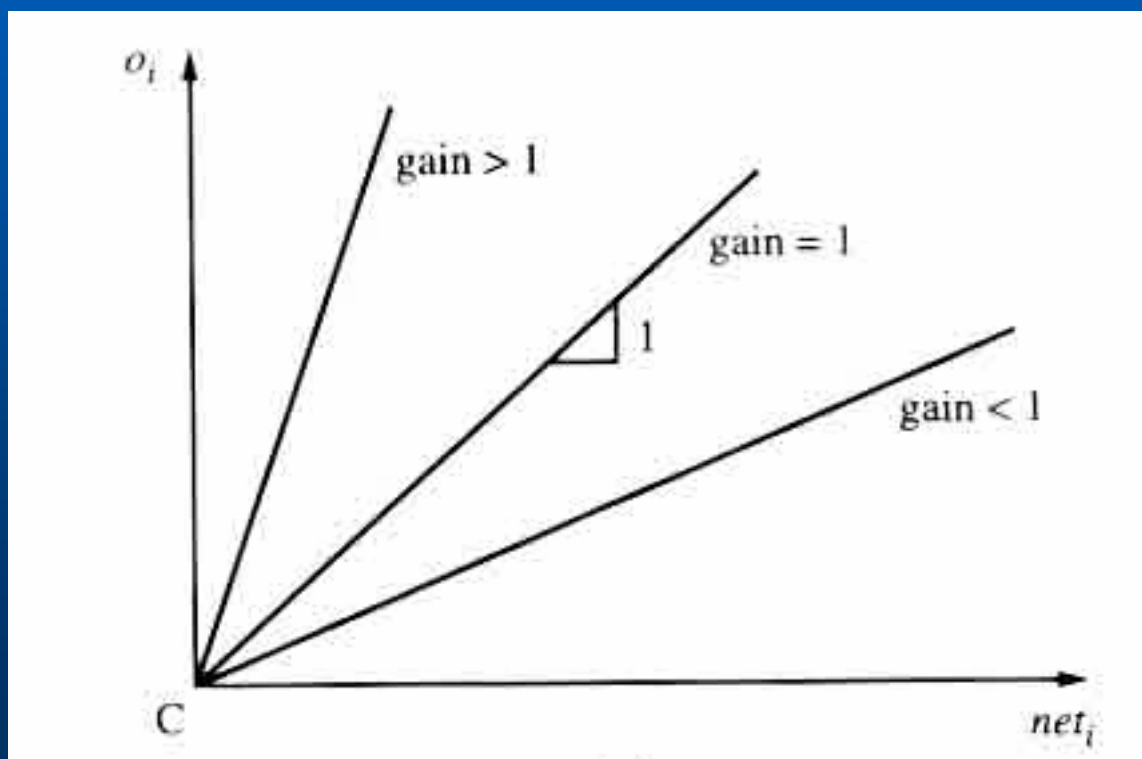



Hard Limit-Linear 轉移函數

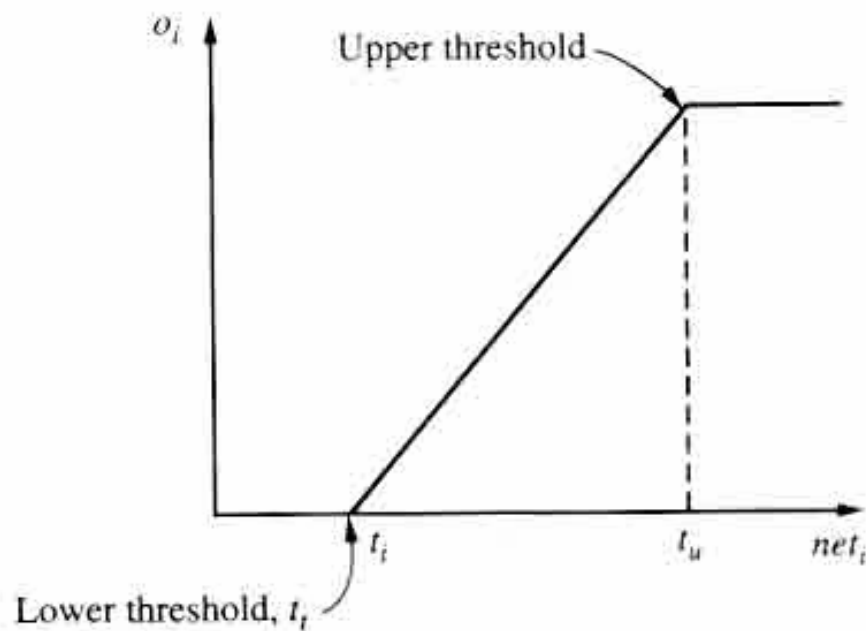
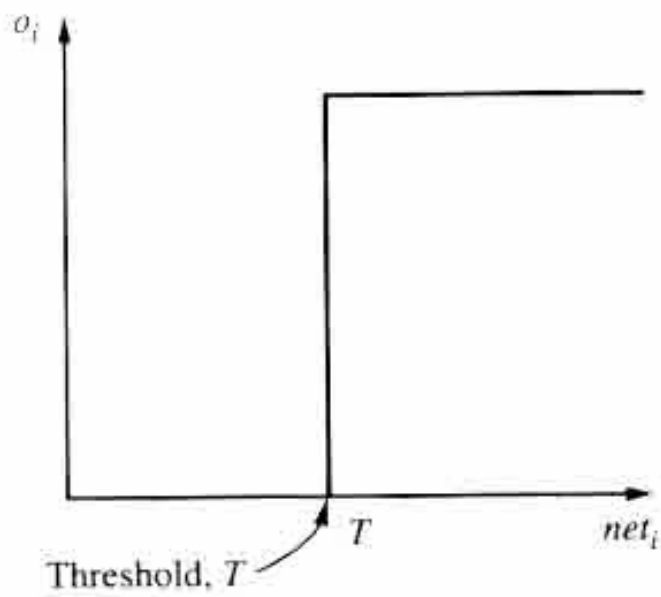



Sigmoid(Logistic)轉移函數

$$o_i = f(\text{net}_i) = \frac{1}{1 + e^{-\text{net}_i}}$$

$$o_i = \frac{1}{1 + e^{-\alpha \text{net}_i}}$$

$$o_i = \frac{1}{1 + ae^{-b \text{net}_i}}$$



Weightless的神經元

$$o_i = \prod_{i=1}^d i_1 i_2 \dots i_d$$

$$\text{softmax} (i_1, i_2, \dots, i_d) = \frac{i_1 e^{-ki_1} + i_2 e^{-ki_2} + \dots + i_d e^{-ki_d}}{e^{-ki_1} + e^{-ki_2} + \dots + e^{-ki_d}}$$

$$\text{softmax} (i_1, i_2, \dots, i_d) = \frac{i_1 e^{ki_1} + i_2 e^{ki_2} + \dots + i_d e^{ki_d}}{e^{ki_1} + e^{ki_2} + \dots + e^{ki_d}}$$



神經網路解題



神經網路的學習

學習(*learning*)意指一個系統調整其系統變數的過程，其目標在於針對特定輸入值產生對應的輸出值。

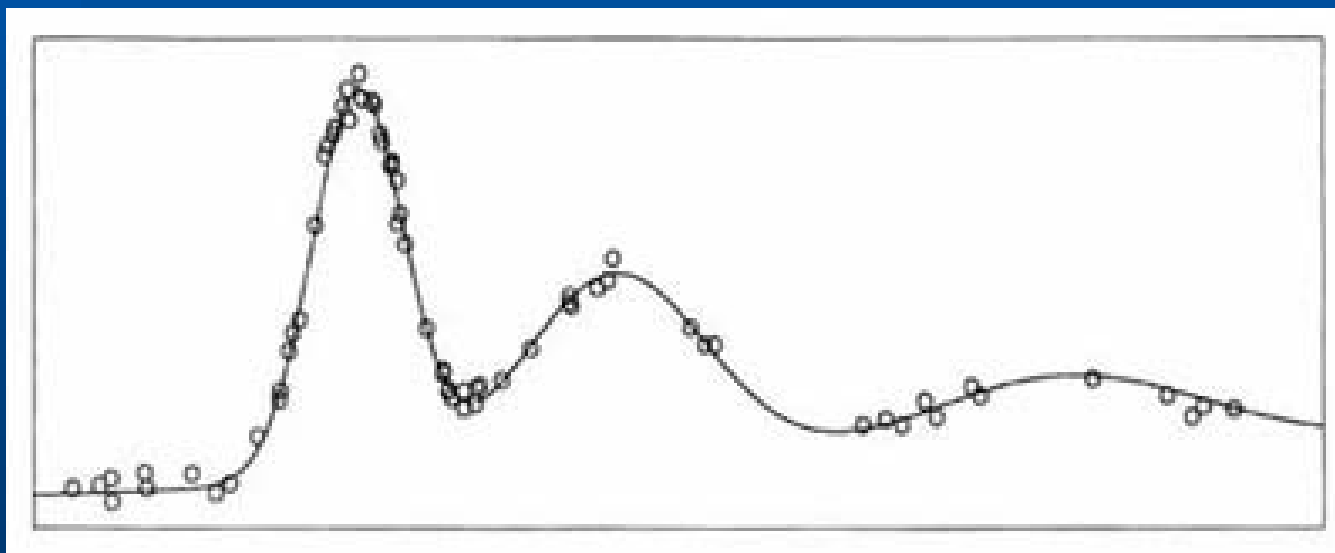



神經網路學習方法論

1. 問題的形式化(Formalization)：變數的選擇和表示
2. 準備學習的資料(data preparing)
3. 決定系統(神經網路)的模型和結構
4. 選擇評估函數(objective function)
5. 選擇最佳化的方法：調整系統參數使得誤差最小
6. 先驗的(Prior)學習法則或啟發式的(heuristic)知識
7. 泛用化(Generalization)



神經網路學習的架構

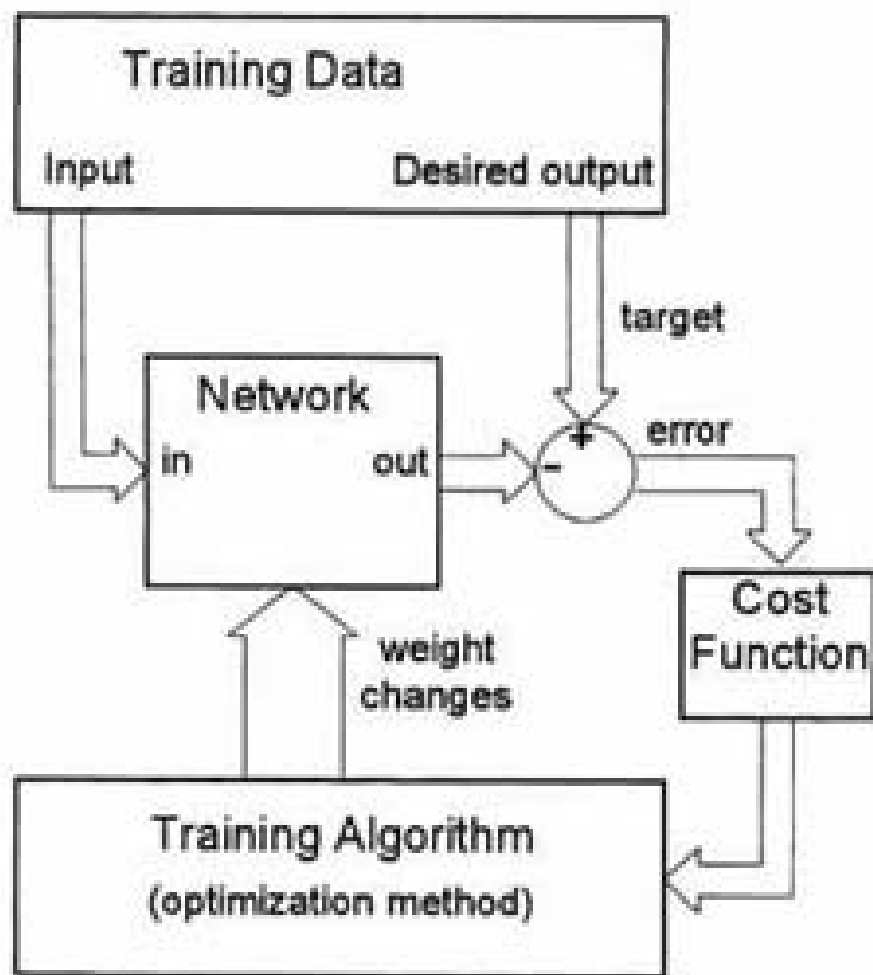



評估函數

用來度量神經網路學習性能。

sum of squared errors :

$$E_{SSE} = \sum_p \sum_i (t_{pi} - y_{pi})^2$$

mean-squared error :

$$E_{MSE} = \frac{1}{PN} E_{SSE}$$



評估函數圖解

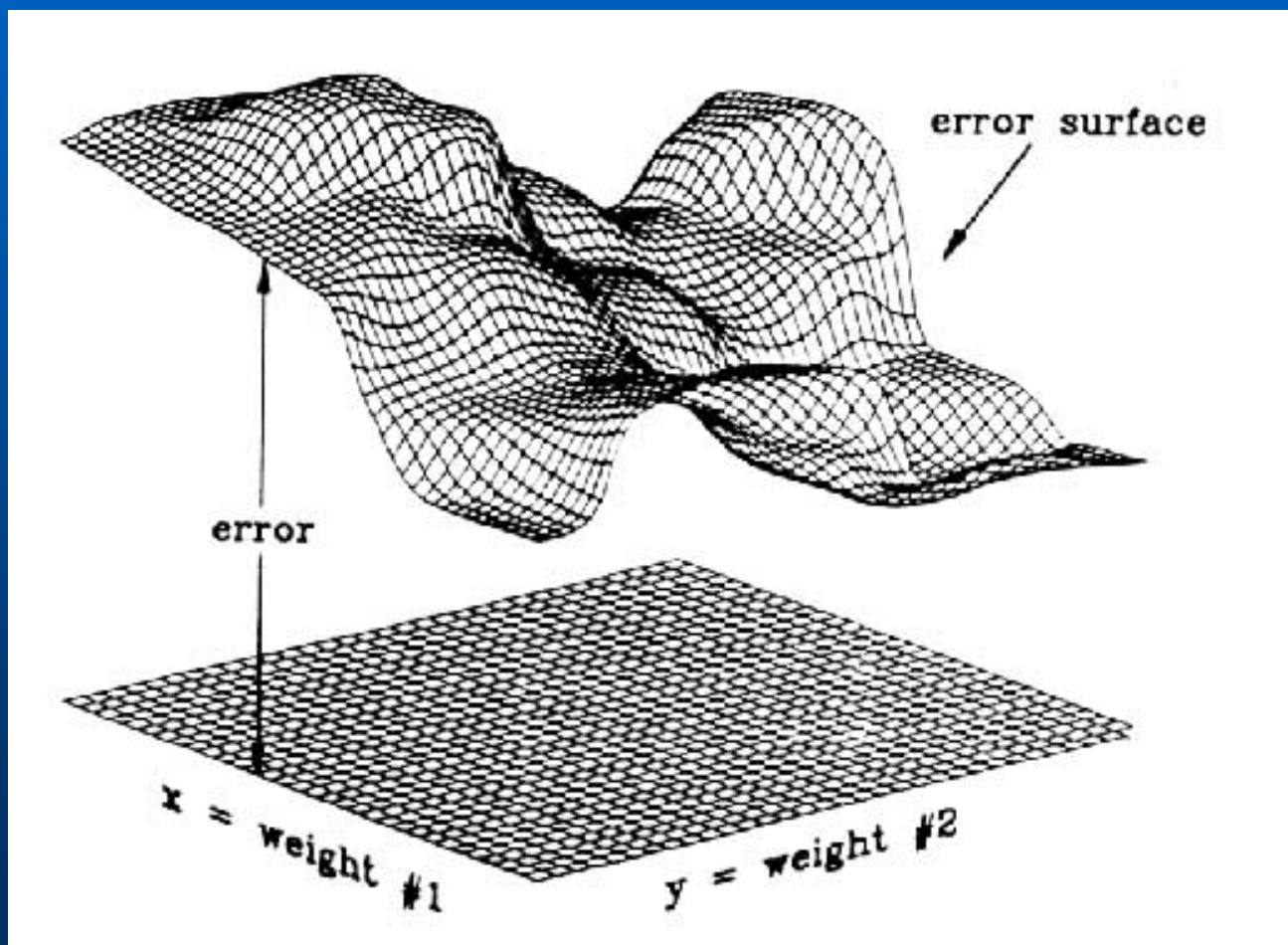



學習解決分類問題

線性可分離

線性不可分離

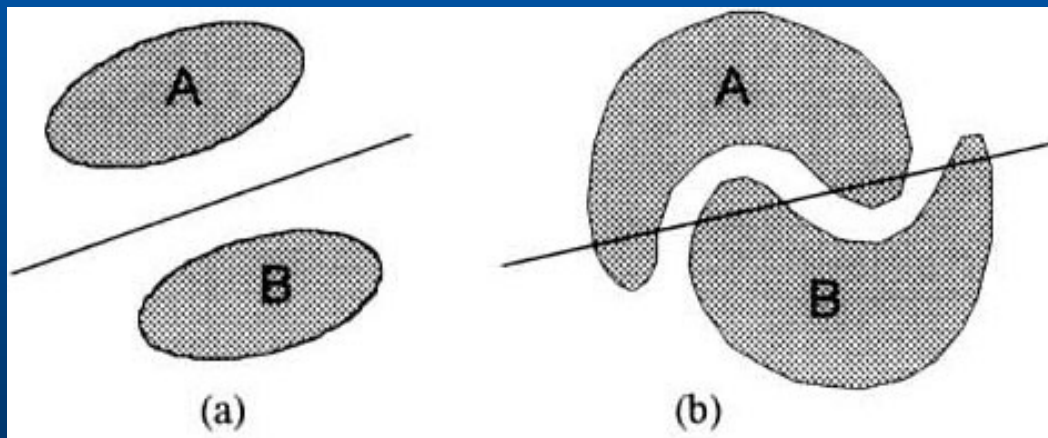



神經網路解題特色

| Characteristics | Von Neumann Architecture Used for Expert Systems | Artificial Neural Networks |
|-------------------------------|--|---|
| Processors | VLSI (traditional processors) | Artificial Neural Networks; variety of technologies; hardware development is on going |
| Memory | Separate | The same |
| Processing Approach | Processes problem one rule at a time; sequential | Multiple, simultaneously |
| Connections | Externally programmable | Dynamically self programming |
| Self learning | Only algorithmic parameters modified | Continuously adaptable |
| Fault tolerance | None without special processors | Significant in the very nature of the interconnected neurons |
| Use of Neurobiology in design | None | Moderate |
| Programming | Through a rule based shell; complicated | Self-programming; but network must be properly set up |
| Ability to be fast | Requires big processors | Requires multiple custom-built chips |



神經網路解題特色

| | |
|---------|--------|
| 傳統DSP | 神經網路 |
| 決定論訊號處理 | 統計訊號處理 |
| 線性 | 非線性 |
| 資料無關 | 資料相依 |
| 無記憶系統 | 動態系統 |



神經網路解題範例

輸入

Computer

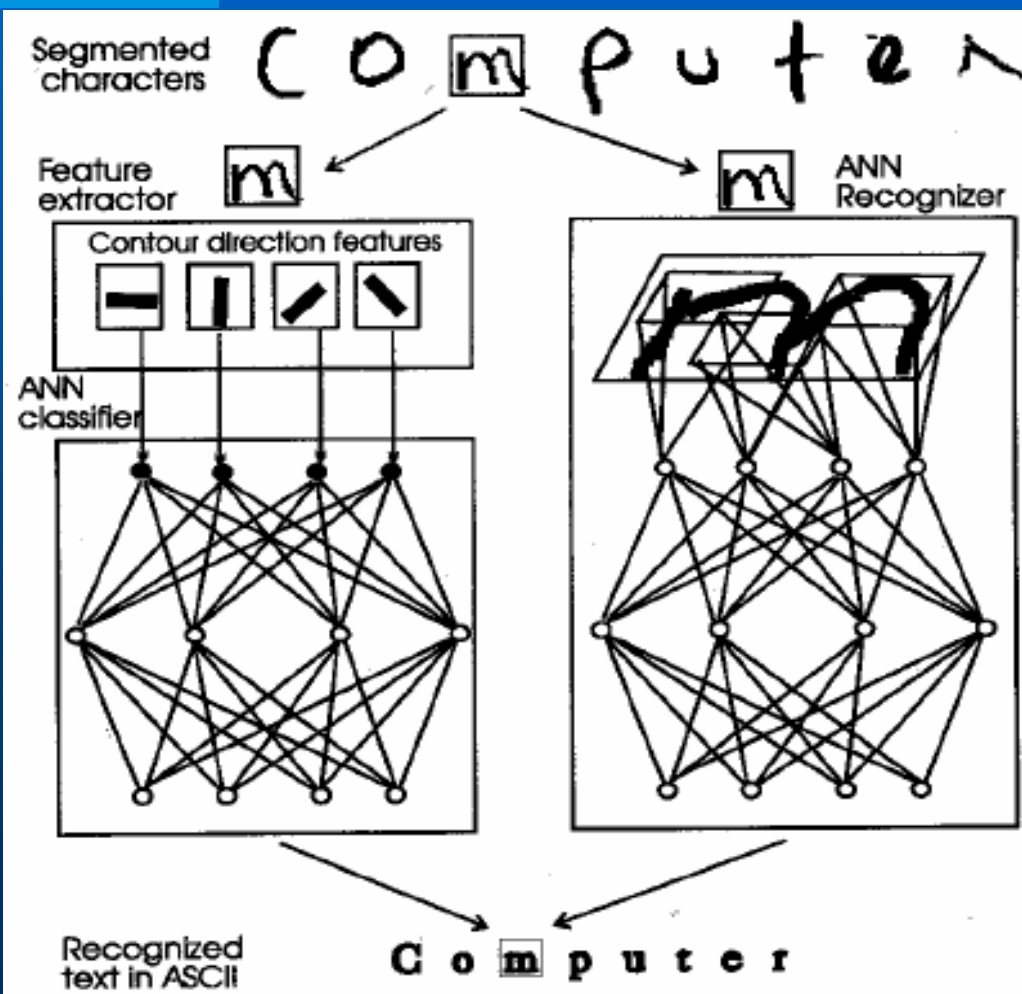



神經網路的應用



神經網路應用：分類

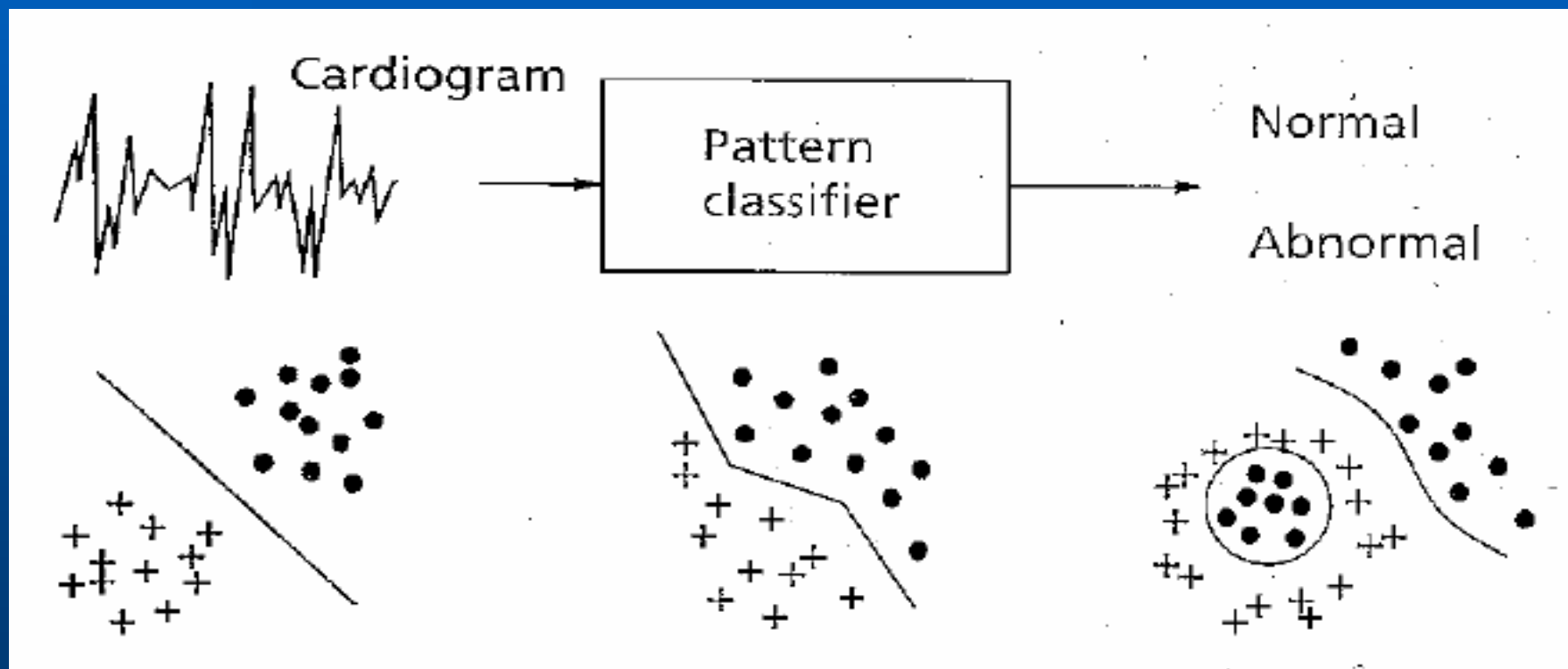



神經網路應用：群組分析

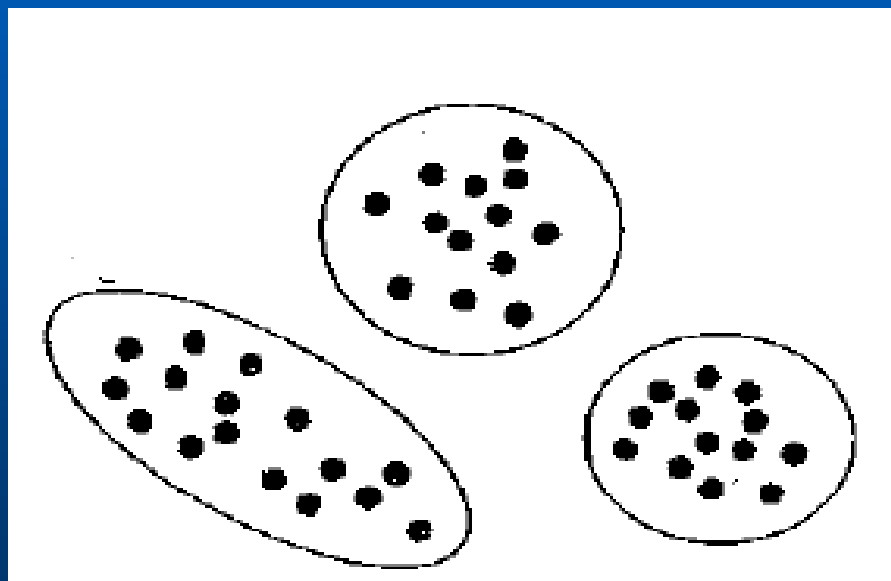



神經網路應用：建模

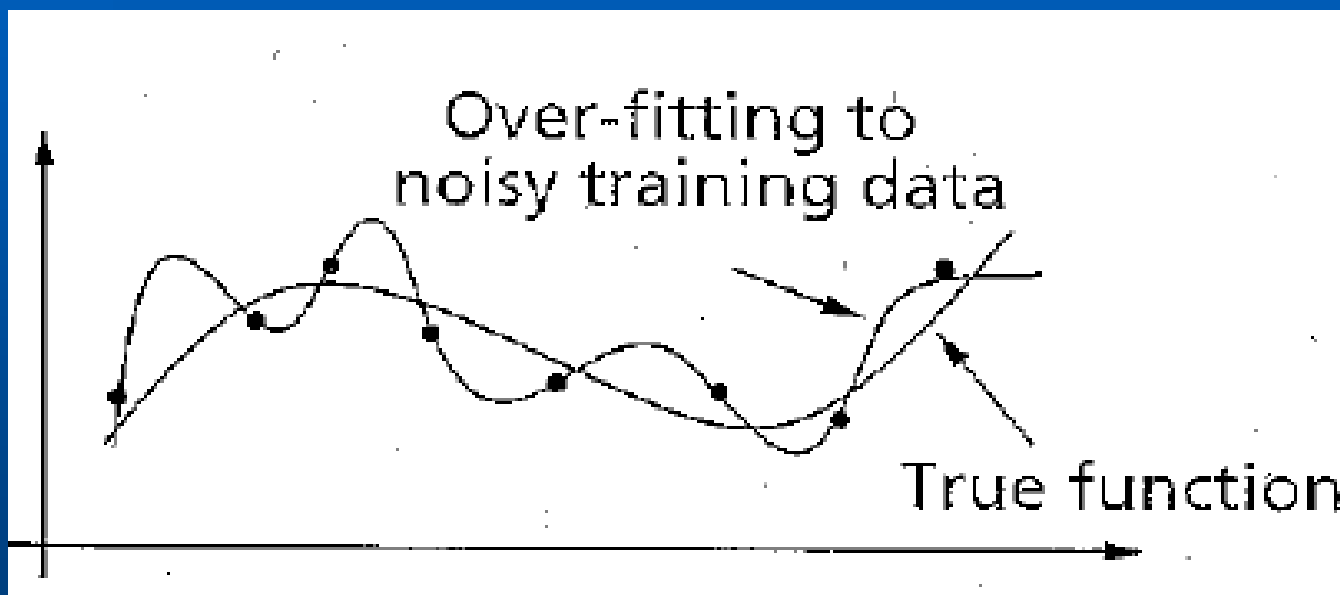



神經網路應用：預測

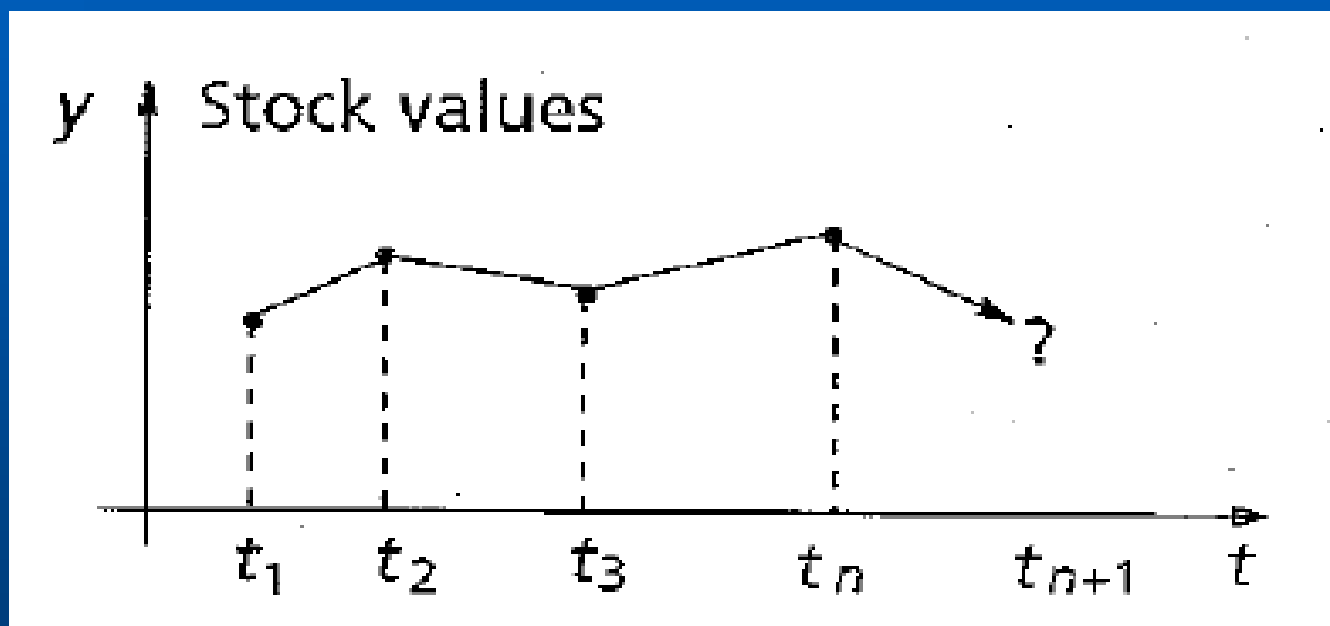



神經網路應用：組合最佳化

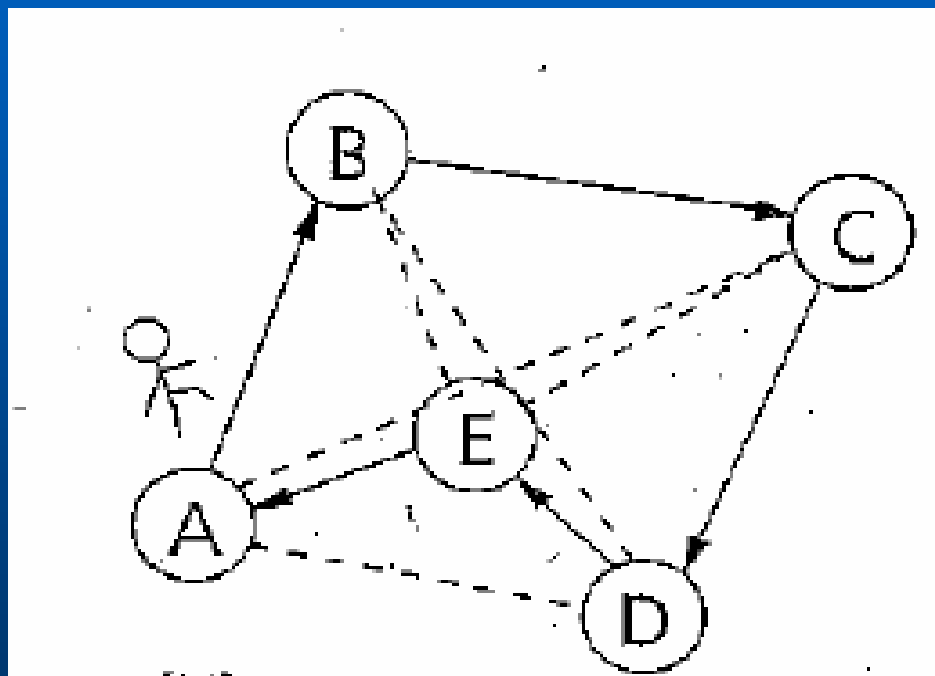



神經網路應用：資訊擷取

Airplane partially
occluded by clouds

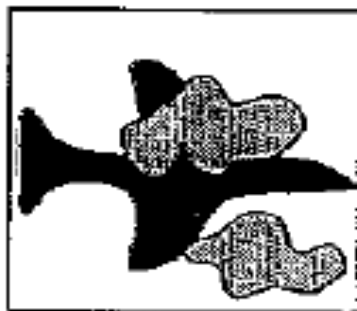

Associative
memory



Retrieved airplane

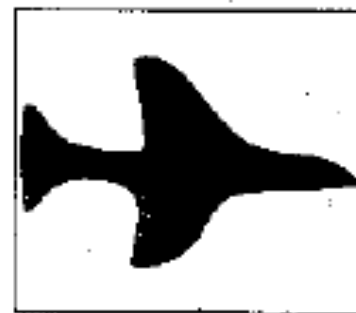



神經網路應用：控制

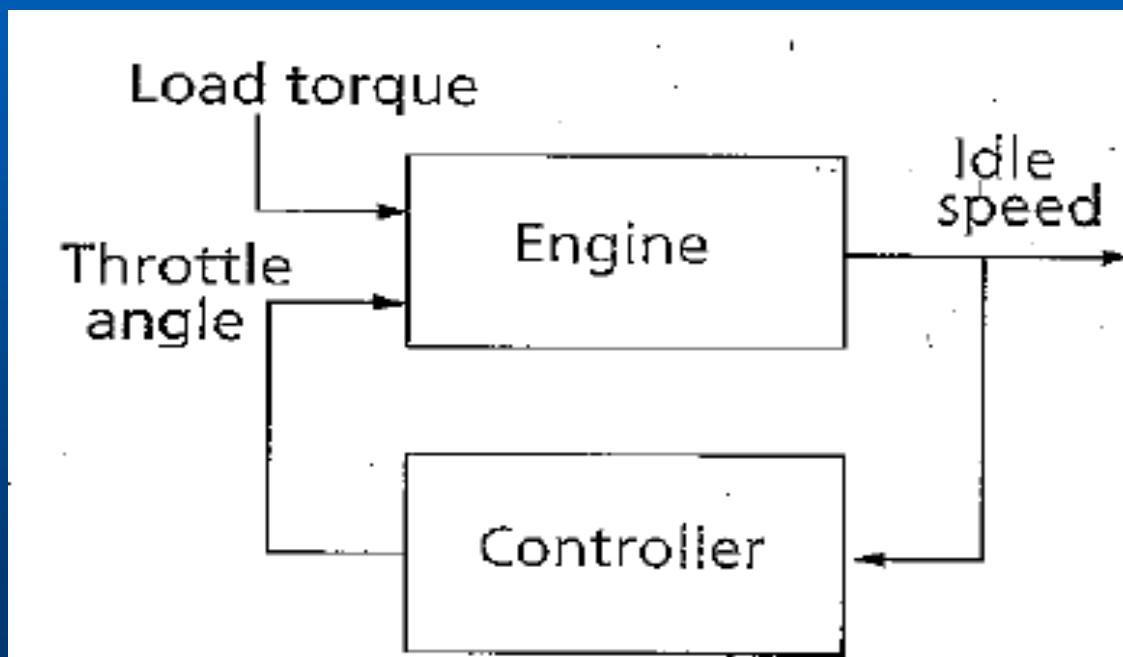



神經網路應用：知識探勘

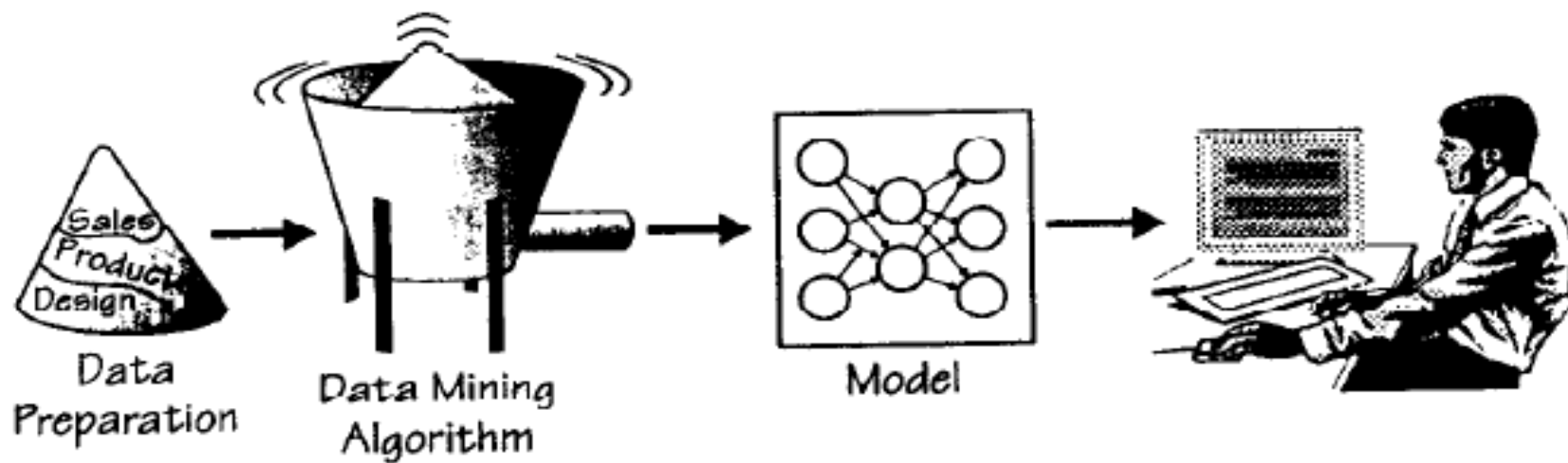



神經網路應用 (MIAT)

數位變焦

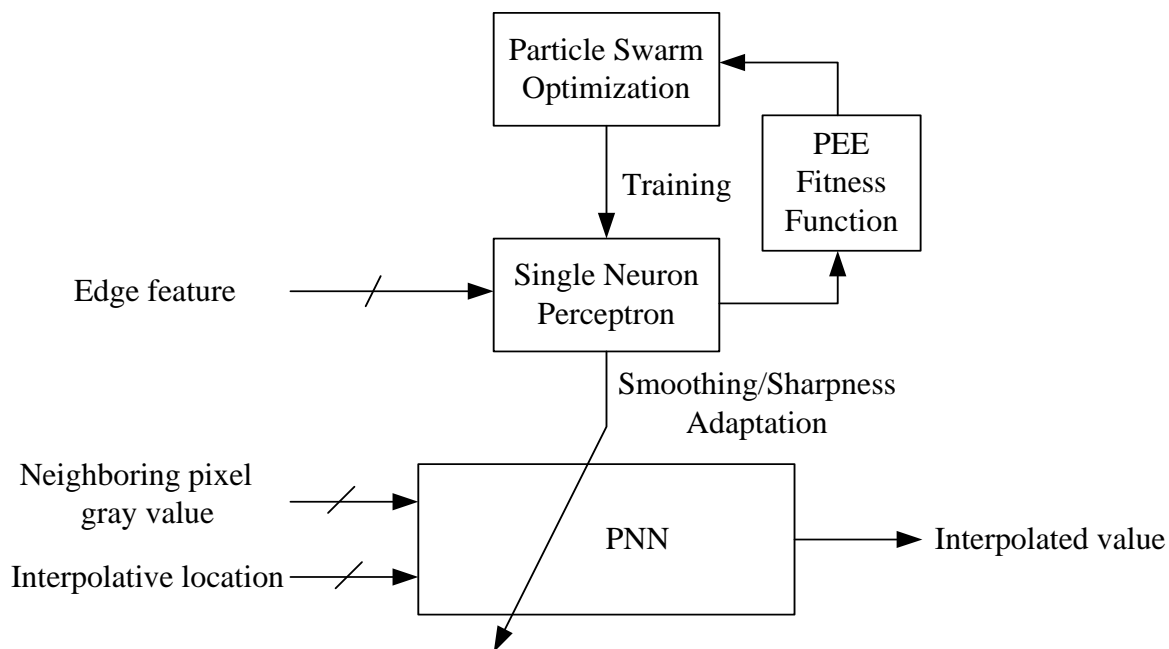



神經網路應用(MIAT)

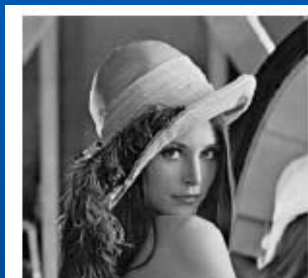

原始影像

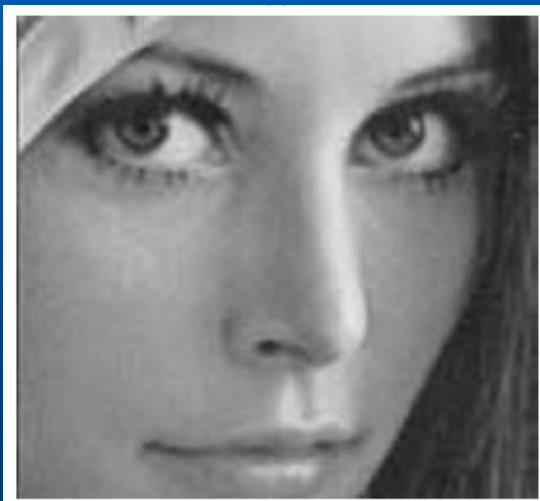

現有方法變焦

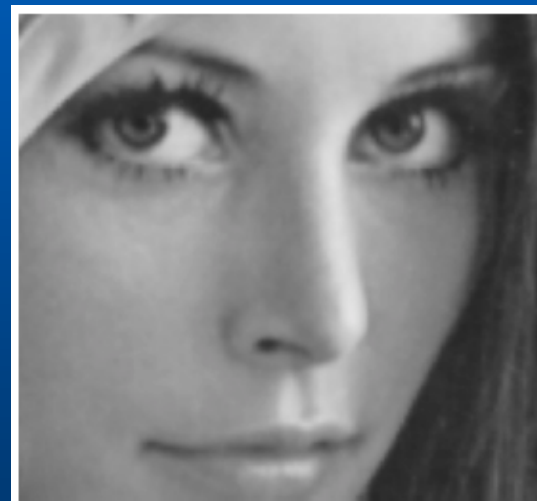

神經網路變焦



神經網路應用 (MIAT)

自動對焦

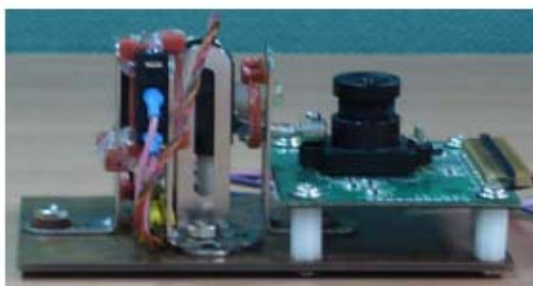

(a) The servo motor and adjustable lens.

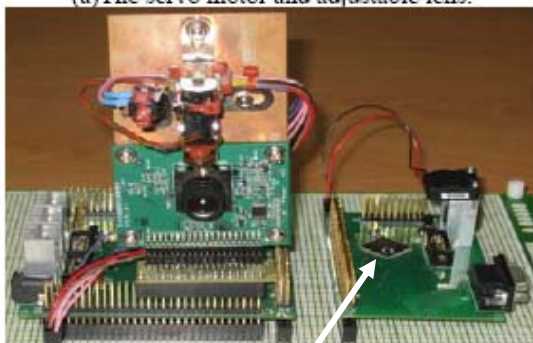

(b) The FPGA (left) and MCU (right) modules.

神經網路控制器



Frame 1



Frame 2



Frame 3



Frame 4



Frame 5



Frame 6



Frame 7



Focused frame



神經網路應用 (MIAT)

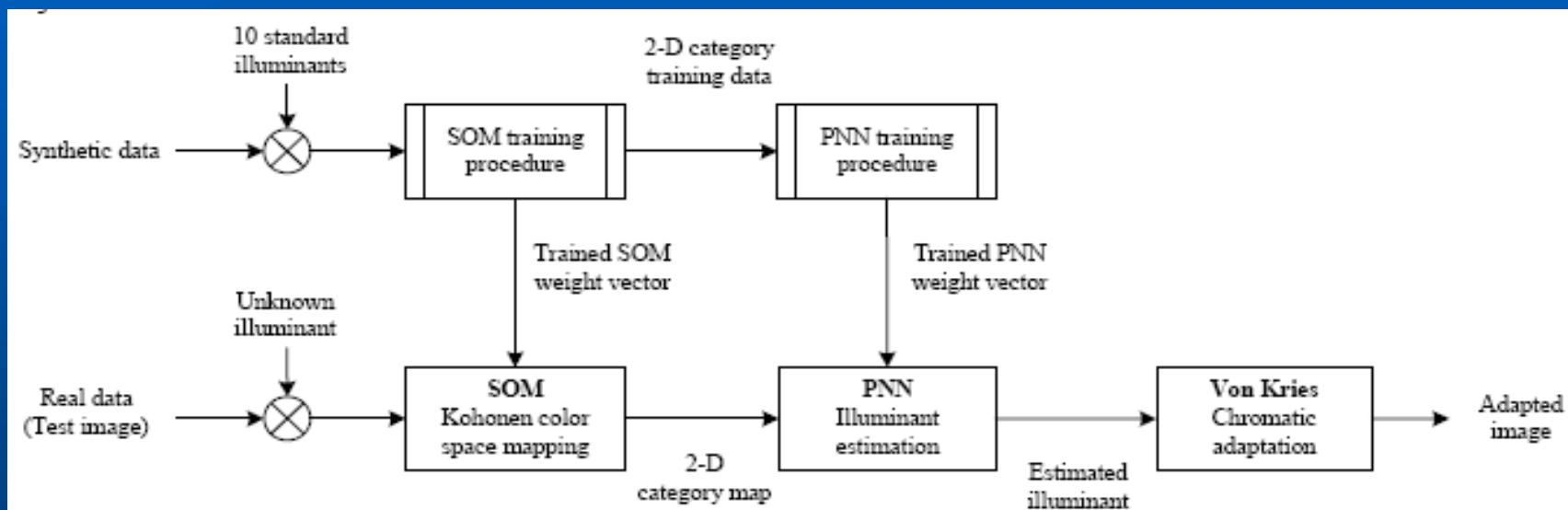

自動白平衡



神經網路應用(MIAT)

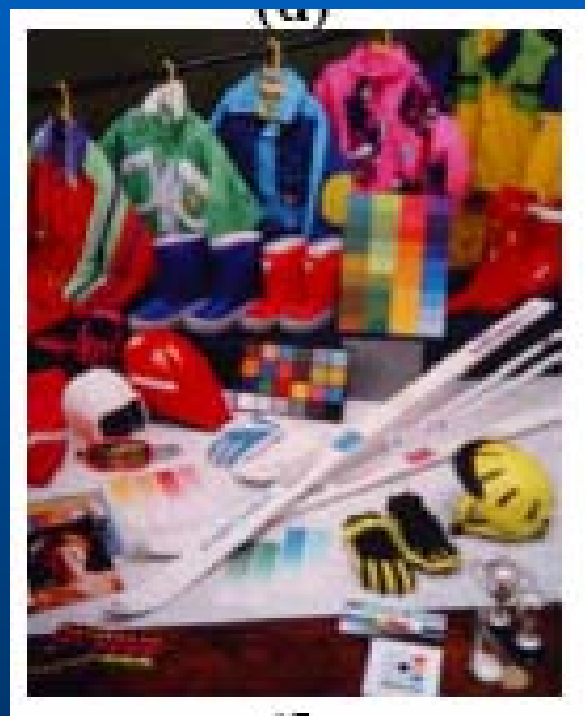

自動白平衡



神經網路應用(MIAT)

自動倒車入庫系統

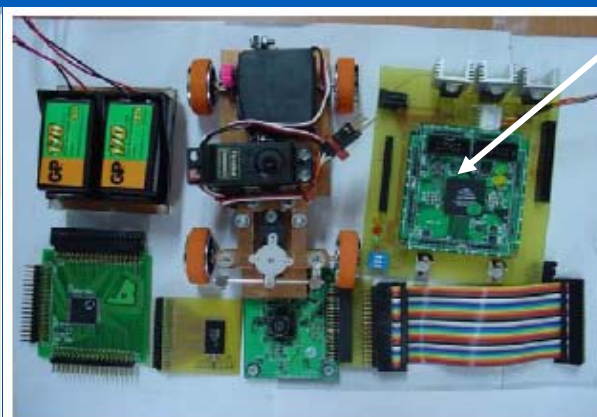

神經網路

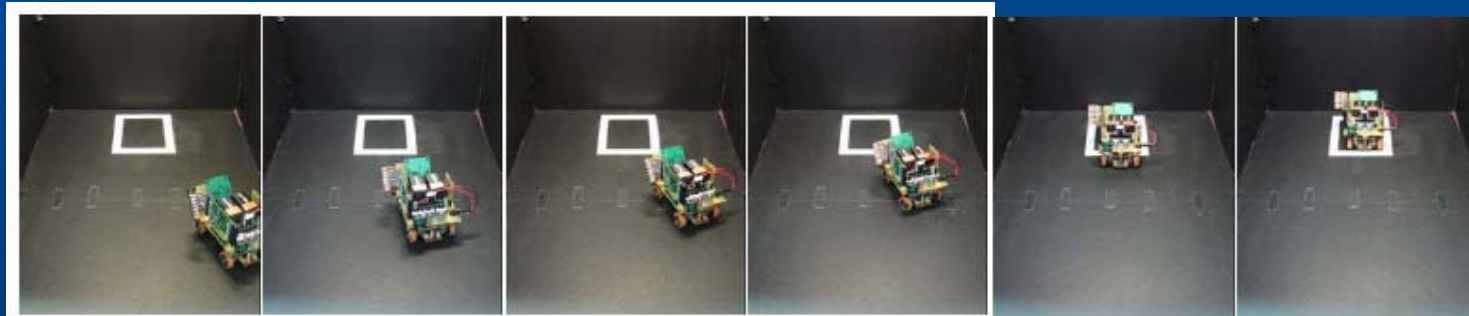



神經網路應用(MIAT)

指紋辨識

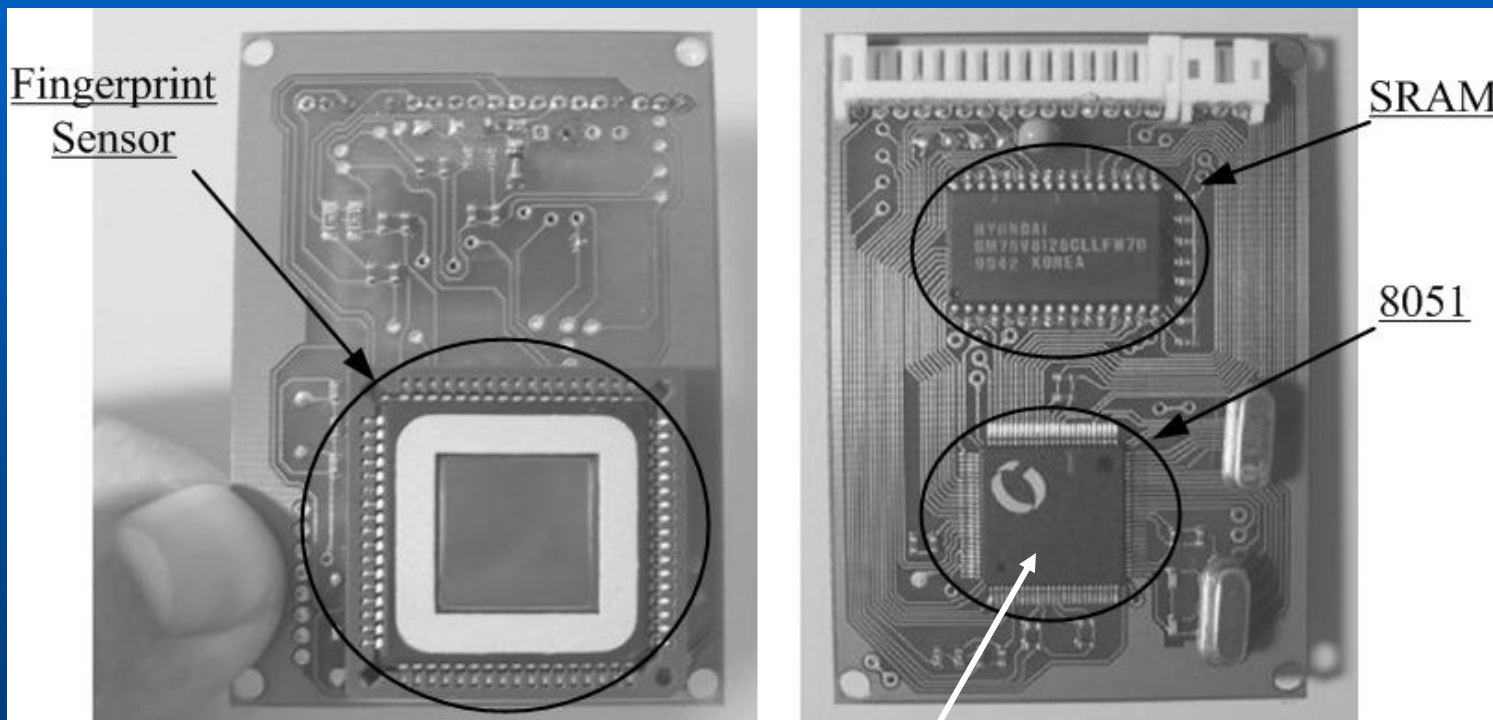

神經網路



神經網路應用 (MIAT)

人臉和虹膜辨識

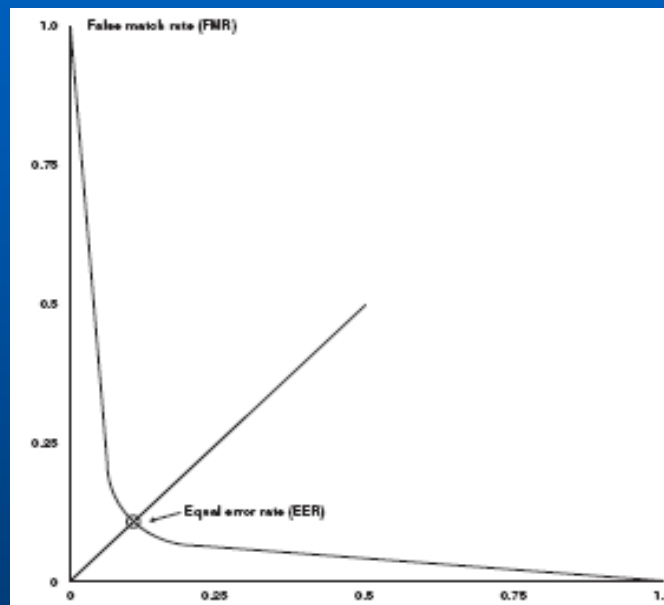
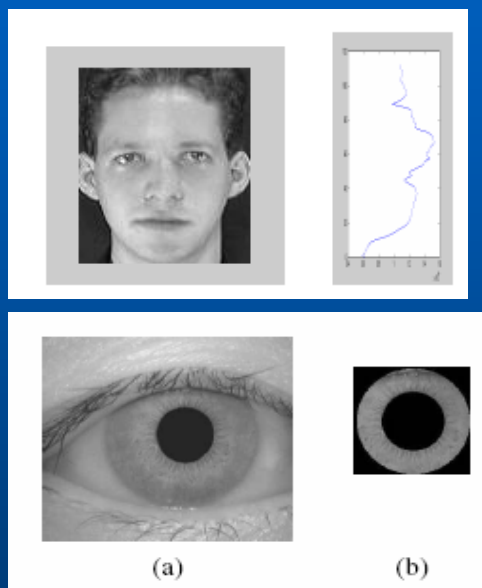

| | ORL Face | Iris | Integration |
|-------------|----------|-------|-------------|
| Best EER | 1.76% | 0.02% | 0.00% |
| Average EER | 3.83% | 1.25% | 0.33% |



結語

人工神經網路仿倣大腦相互鏈結的神經網路，進行案例的學習和自組織，可從大量資料歸納出有用的知識模型。

人工神經網路由分散的、平行的處理單元所組成，可對非線性、複雜的現象進行建模。

人工神經網路並非來自解析模型，而是一種泛用的解題機器(problem solver)。